

UNDERSTANDING YOUR RADIO

Parts of this article were originally published in sections starting in December 1993 when I was writing for the club newsletter. Although I do not profess to be an expert on radios, I do have a basic understanding of their operation. This basic understanding has helped me in analyzing problems in the past and may do the same for you.

Reprint of this article is only allowed with my easily obtained permission - Al Coelho

The use of Radio Control in our hobby has advanced drastically since its use in the 40's, to our present day systems. Original systems only transmitted a carrier wave signal, which when detected activated an electromechanical device know as an escapement. These escapements were rubber band powered and the systems were basically single channel operation.

Refinements to the systems transmission included the use of superhetrodyne receivers and tone modulated transmission. The galloping ghost system with its motor driven, constantly wagging, tail was the first proportional system. And the reed systems with their vibration sensitive reed banks were our first multi channel units. All of these systems are antiquated by today's standards and most would not even work in our current overcrowded radio environment.

The digital proportional control system we use today emerged in the 60's. The "Digitro", a 3 channel system designed by Ed Thompson, was originally a construction project in Radio Controlled Modeler magazine. World Engines began kitting the design in 1966 and the digital evolution began. Although much refinement to the components has been done, the basic design is still what is used in today's modern PPM systems.

Table of contents

The Servo: Here we cover the operation of a servo which addresses the basics of our system.

The Encoder: Here we address the conversion of stick movement into an encoded signal suitable for transmission.

The Decoder: Here we address the recovery of the encoded signal and returning it to the format used by the servo.

Radio Transmission: Here we address the particulars of Radio transmission as used by our hobby.

Batteries: Here we address the care and feeding of our battery systems. (This section not available)

This article has been broken into five section covering the basic parts of the system. You may go directly to a section by clicking on the link in the Table Of Contents above.

Download an Acrobat format version

This document is available in an Adobe Acrobat (version 4) format for local viewing and printing. The Adobe Acrobat reader can be obtained free of charge at [Click here for Adobe site.](#)

[Click here for this document in Acrobat format](#)

Section I - The Servo

In order to understand the working of our systems, we must first understand the basic operation of a servo. The servo we use today has evolved from a design implemented with the first proportional radios back in the 60's.

Let us look at one channel on your radio. At the transmitter we have a stick who's sole purpose is to control the "**Length**" (or width) of a pulse sent to your servo. How we generate and send this pulse in the transmitter, and how we receive and decode this pulse in the receiver, I will address later. For now lets accept that this occurs and see what happens.

Today's servos all use the same basic concept that the length of the pulse received controls the output arms rotational position. Although some of the early radio's used different pulse lengths, all current radios that I know of use a standard for the length of the pulse.

When your transmitter stick is centered, the pulse generated is 1.5 ms (milliseconds) long. As you move the stick to one end of its travel the pulse

either lengthens or shortens .5 ms (depending on the setting of your servo reverse switch to be explained under encoding). Looking at this overall we see that the pulse length then varies from 1.0 ms to 2.0 ms, with 1.5 ms being the center.

Now the goal of all transmitters is to encode this pulse onto a radio signal which can be received by the receiver and decoded back into the original pulse. What we get on the signal wire, going to the servo from the receiver, is a pulse which is varied in length from 1.0 to 2.0 ms depending upon where the transmitter stick is.

Now how does the servo know where to rotate it's output arm to based on this pulse? For this we must look at the basic operation of the servo. (Referring to Figure 1)

Internally within a servo is its own pulse generator which generates a pulse which varies in length based on where the output arm is. Like the transmitter stick, the output arm moves a "variable resistor" (called a "pot" for short). This varies the internal pulse generators pulse length from 1.0 to

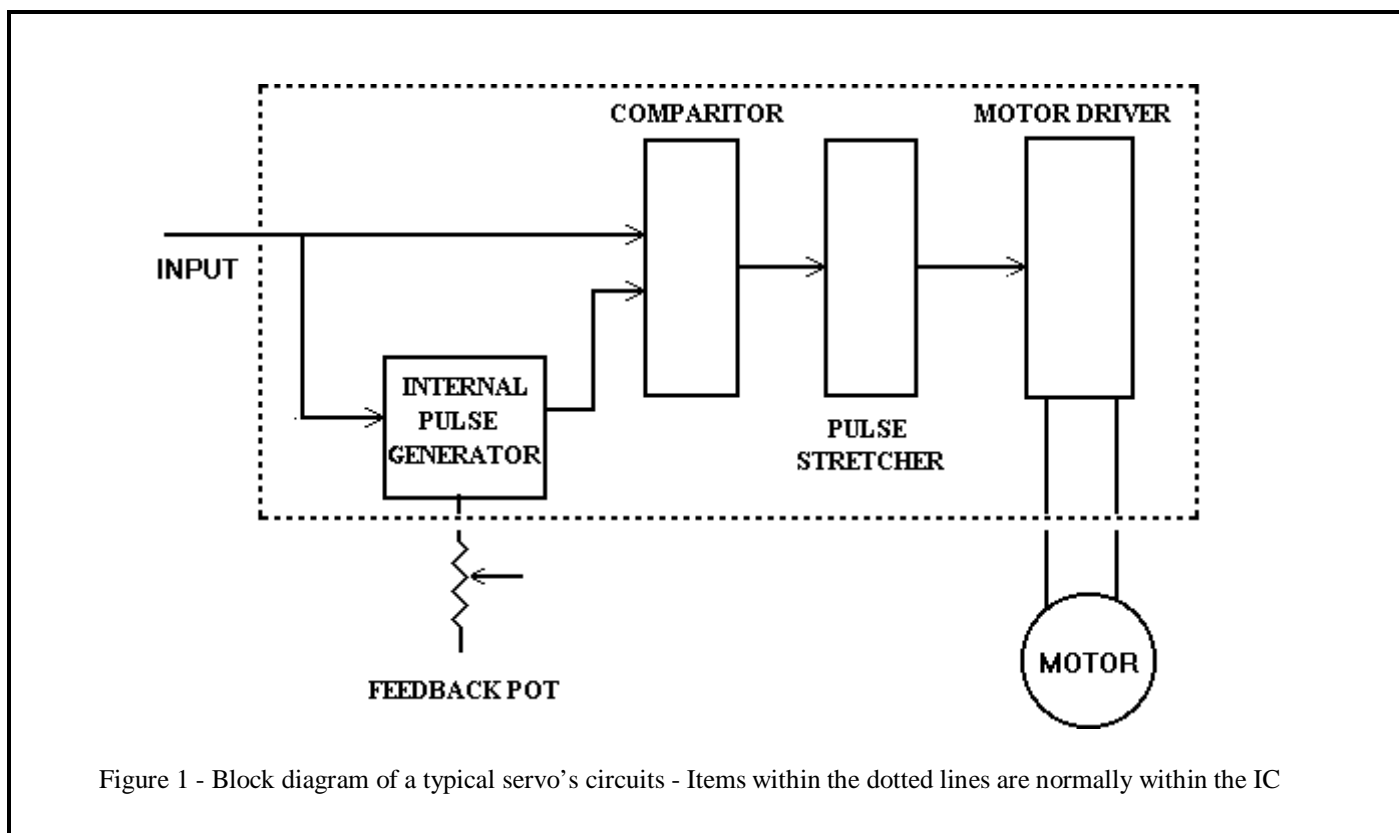

2.0 ms with the pulse being 1.5 ms when the arm is in the center (just like the transmitter stick!).

The pulse generator within the servo only generates a pulse when an incoming pulse is received from the receiver. The receiver pulse “triggers” the servo’s pulse generator. What we now have in the servo is two pulses, the pulse from the receiver and the servo’s internally generated pulse. Both pulses start at the same time, but depending upon the position of the transmitter stick, versus the position of the servo arm, they may not end at the same time.

Lets first look at the operation when both the transmitter stick is centered, and the servo arm is centered! Under this condition the incoming pulse would trigger the servo pulse and both pulses would start at the same time, and end together 1.5 ms. later. When this occurs the servo does nothing.

Now let’s move the transmitter stick in one direction, and as stated before we will alter the length of the pulse to the servo. For this example we will say that the pulse became longer. As before, the input pulse triggers the servo’s internal pulse generator and the two pulses start together, but this time the input pulse is longer than the servo’s internally generated pulse and they don’t end together.

We will now introduce the second circuit in your servo called a “pulse length comparator”. This circuit gets input from the incoming signal and the internal pulse generator, and as its name implies, compares them. The output of the comparator will be a signal which either indicates that both pulses are equal in length, the incoming pulse is longer, or the incoming pulse is shorter. How much longer or shorter the incoming pulse is versus the internally generated pulse does not matter.

Now enters the motor driver circuit. This is the circuit which applies power to the servo motor. The servo motor is a DC motor, which means, if we connect the power to its terminals one way it will turn in one direction, and if we reverse the polarity of the connection it will run in the opposite direction. The motor driver circuit does just that.

Depending upon the signal it receives from the pulse comparitor, it will either run the motor clockwise, or counter clockwise.

Let us assume that for this condition, where the input pulse is longer than the internal pulse, that the motor is run clockwise. This in turn rotates the output arm which is connected to the “feedback pot”. As the output arm rotates, the length of the servo generated pulse increases. The servo will continue to rotate until the “pulse length comparitor” senses that they are both equal in length, at which time the motor driver circuitry will turn off the motor.

If we were to move the stick a little further in the same direction, the pulse comparitor would once again detect a longer input pulse and signal the motor driver circuitry to start the motor running clockwise again until the pulse lengths match.

If we were to return the stick to neutral, the input pulse would be shortened, the pulse comparitor would detect this shorter input pulse and signal the motor driver to run the motor counter-clockwise until the pulses matched.

What we now see is that our servos are “error correcting” and not “self centering” as we may have thought. By this I mean that the servo only moves when it receives an input pulse which does not match its internal generated pulse. If we were to loose the signal to the servo it will remain where ever it was last positioned.

In order for our servos to faithfully track the transmitter stick position, we must constantly provide it a stream of input pulses for it to compare and adjust to. When we get to transmitter and receiver operation we will address the “frame rate” (repetition of pulses) which is sent to the servo, but for now we will just say that the servo receives a input pulse about every 20 ms, or about 50 times a second.

For those wondering , the servo motor is not pulsed 50 time a second when it is moving. The output of the “pulse length comparator” feeds a “pulse stretcher” which in turn feeds the “motor driver

circuitry". The function of this pulse stretcher is to "stretch" the small differential pulse generated by the comparator long enough for the next pulse to arrive.

Servo evolution - Originally our servos were quite large, due mostly to the fact that the electronics portion was constructed of discrete components (individual transistor, resistor, & capacitors) and the unavailability of high performance small motors.

With the increasing popularity of RC, manufacturers began developing integrated circuits and motors especially for our hobby. What we now have is extremely small, yet reliable, servos (and radios) at a lower cost.

4 wire servos - Although many of you may never have seen one, early servos used 4 wires instead of 3. These servos are not really usable on today's receivers.

These early servos used a 2.4 V motor versus the current 4.8 V. The battery packs were center taped and the motor driver circuitry did not reverse both motor leads. The center tap of the battery was attached to one terminal of the motor and the motor driver circuitry then switched the other motor lead to one end or the other of the battery (achieving the same end results).

Although these servos could be retrofitted to one of today's radios by center taping the battery pack, it is

hardly worth the effort as their output torque was low.

Negative pulse servos - All of today's major manufacturers use similar integrated circuits in their servos which use a "Positive" input pulse. This means that the input pulse goes positive for the duration of the input signal.

In the early days, some manufacturers used negative input pulse servos. Negative input servos cannot be used on a positive pulse system or vice versa.

Interchangeability - To my knowledge, all of today's servos are interchangeable between manufacturers **if you alter the plug**. If you alter the plug does not mean just changing it to fit in the hole, **but also ensuring that the three wires are correctly oriented**. Specifically, Airtronics puts the + power lead (red) on the outside, while JR, Futaba, & High Tech place the + power lead in the center. To use an Airtronics servo on JR, Futaba, or High Tech you must alter the position of the power leads in the plug. Likewise to use JR, Futaba, or High Tech on an Airtronics they must be altered to the Airtronics configuration.

Although there is a slight design difference in the connectors (See Figure 2), all of them are now using the .1 inch pin spacing, and with a little rework the JR, Hi Tech, and Futaba plug can be made to cross fit between radios. Looking at the Futaba plug from the end you will find a tab coming out the side which is used to "key" it into the socket. If this tab is removed, and the edges are beveled, then the plug will fit into JR or High Tech. **Watch out because you no longer have the keying tab to prevent you from plugging this in backwards in the Futaba**. The JR or Hi Tech plug, with the above precaution, will fit into a Futaba without change.

Reversing Servo Rotation - With today's servo reversing transmitters, you rarely have a need to reverse the direction of a servo. In early transmitters there were no servo reverse switches, and you had to be careful installing the servos and push rods to ensure that the control surfaces moved

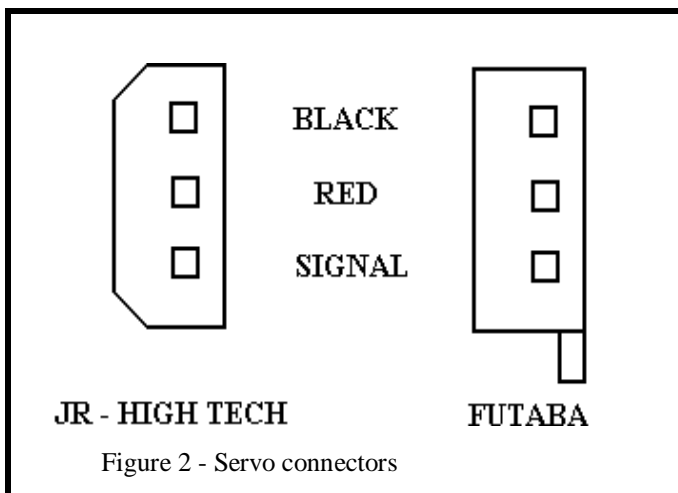

Figure 2 - Servo connectors

in the right direction.

If you should have to reverse a servos rotation, remember that **you cannot reverse a servo by just reversing the wires on the motor.** You must also reverse the two outside wires across the feedback pot.

Servo Buzzing - Servo buzzing is a condition where your servo “buzzes” while sitting still. There are many reasons for this, most of which are not correctable.

Tight Dead Band - When a servo is designed, the dead band is made as small as possible. The dead band is the amount of stick movement that is required before the servo begin to move. It cannot be set to “0” or else the servo will buzz, but if it is to wide then the stick response is not good.

If you have one servo that buzzes periodically then it probably is a “tight dead band servo” and there is nothing you can do about it. If all of your servos buzz then you probably have a high battery or receiver overdrive condition.

High Battery Voltage - Some radio’s will buzz, when the battery has just been charged, and the buzzing will go away after a few minutes of operation. You must remember that when we first take our batteries off the charger, a 4.8 volt receiver pack will measure about 5.8 volts and a 9.6 volt transmitter pack may measure as high as 11 volts. This overcharge condition is normal and will bleed off to the normal voltage rapidly. This high voltage coupled with either a tight servo deadband, or possibly the following receiver over driving condition may cause buzzing and is nothing to worry about..

Receiver Overdriving - Our receivers are expected to work beyond our range of sight, yet we also expect them to work when our transmitter is 1 foot away from the receiver. This is asking a lot, but most units do handle it. If your servos are buzzing, try moving your transmitter about 10 ft. away from the plane and see if the buzzing stops! If it does, don’t worry about it. The Automatic Gain Control (AGC) circuitry is just being over driven when the

transmitter is too close. This may only happen in conjunction with the overcharged batteries.

Dirty Pots - Dirty servo pots (feedback potentiometer) will normally show up as jitter on the servo or jerky operation. Since most of the time your servo is sitting in neutral, vibration may cause wear on the pot surface. This will show up as jitter when the servo is sitting in neutral. Usually when this occurs the pot face also gets dirty and the servo responds unevenly to stick motion. (Like little jerks getting to where its going).

If your servo jitters in neutral try moving the trim lever to one end and then the other. If the jitter stops at one extreme or the other then you probably have a dirty pot. The jitter stops because you moved the pot wiper arm off the worn center spot.

When jitter occurs due to a dirty pot, the only good fix is to replace the feedback pot. Cleaning seldom lasts long and on most of the new servos the pot is a sealed unit.

Output arm bushing wear - If you are running a standard non ball bearing servos you will get output arm bushing wear. This is an egg shape wear in the case top where the arm runs and is only fixable by replacing the case top. To determining if you have wear, wiggle the arm and see if it moves.

Extremely bad wear will show up as bad control response as the arm merely moves back and forth in the worn hole instead of rotating.

Mounting grommets - Mounting grommets are designed to shock support your servos. The most common problem with servo grommets is that the user installs the eyelet (brass insert) backwards. The flange on the eyelet should be on the bottom against the servo tray or mounting rail. If the servo screw does not have a built in washer (common today) then use a small washer to prevent the servo from coming off over the screw head.

The eyelet in the grommet is to allow you to tighten the screw without over compressing the grommet. If installed backwards, the eyelet will dig into the servo mount and allow over compression of the



grommet. This eliminates all vibration dampening (Thus causing faster pot and output arm hole wear, component failure, etc.).

Gear replacement - Should you crash, (heaven forbid) be sure to check your servos for damaged gears. Immediately after retrieving your plane (or pieces) and before electrically operating the servos, grab the output arm and try rotating it. If it moves freely without rotating the servo's gear train then you probably lost a gear tooth. Now hook up your radio and hold a light pressure on the servo arm while you work the transmitter stick to maximum travel. A missing or damage gear tooth will be easily detected.

Gear replacement is an easy task in a servo. Usually the gear driving the output gear will loose a

tooth. The gears next to the servo motor seldom get damaged, but do inspect them all. If possible before taking the servo apart center the arm. Now when you take the case top off, look for the stop pin cast in the output gear. This is a mechanical stop that hits two stop points cast in the case. When you replace the output gear, its stop pin should be in the same position as the one you took off (centered between the case stop points). Also, the bottom of the output gear is keyed in some fashion to the top of the pot. This must be aligned before installing the gear. With the exception of the output gear, all other gears have no alignment position.

Indirect Drive Pots - In some servos the output gear sets directly on the shaft of the "feedback pot". In fact, early servos used the bushing of the pot as the lower support for the output gear. This

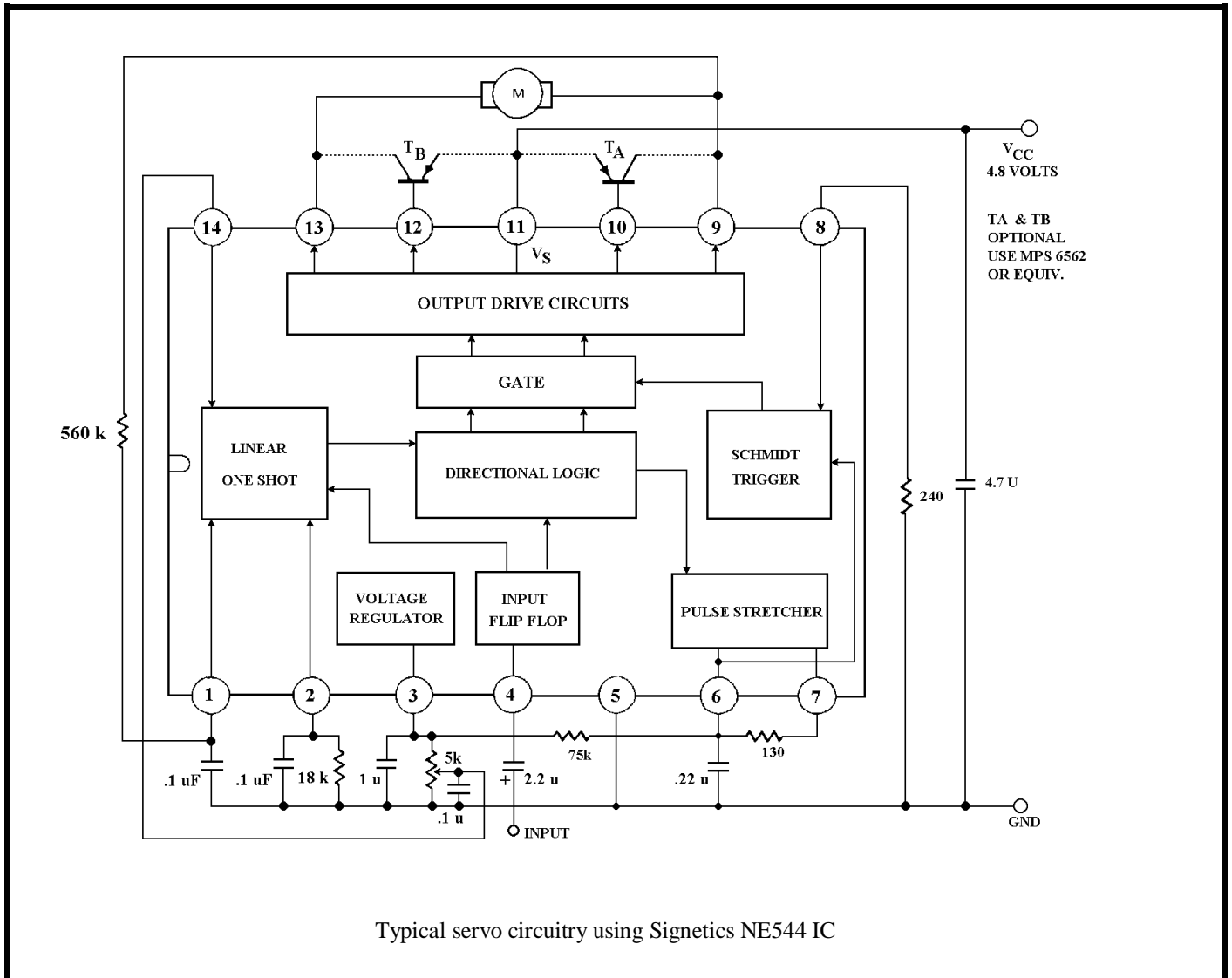

configuration passes all vibration of the controls and rods to the feedback pot causing early wear. To resolve this the output gear in an indirect drive pot servo has been supported on both ends, and a coupler, which reduces the transmission of vibration, is used between the output gear and the feedback pot shaft.

Signetics® & Motorola® ICs

Four of the most popular IC's used in the construction of our radios are the Signetics® NE544 Servo Amplifier, NE5044 Seven Channel RC Encoder, and the NE5045 Seven Channel RC Decoder. The NE5045 decoder is commonly driven by a receiver based on Motorola® MC3361 Low Power Narrow Band FM IF. This section includes the Signetics® NE544 Servo Amplifier. Later sections will include the associated IC used in transmitter and receiver circuits. The circuit presented here is not intended to represent any particular radio manufacturers implementation but to offer a “generic” example of using the NE544 in a servo.

Deadband - The resistor between pin 6 & 7 controls the deadband width. The larger the resistor the wider the deadband (Minimum deadband is spec at 1us with 0 resistance).

Servo Throw - The resistor to ground on pin 2 controls the servo throw or degrees of travel (Normally 60 °). A smaller resistor will increase throw (ie. 15 K = about 75°)A larger resistor will decrease the throw (ie. 22K = about 45°).

Optional Driver Transistors - Most of our standard servo's do not use the optional PNP driver transistors as the chip is rated to drive a 500 mA load.

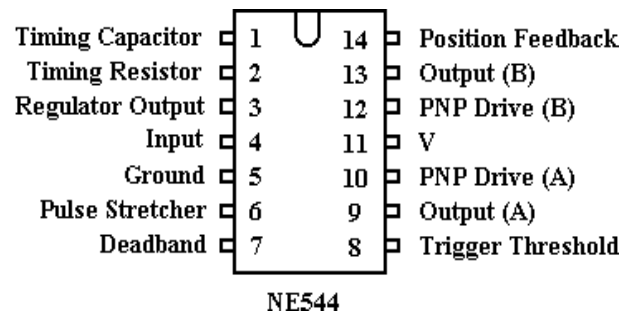

- **500mA Load Current Capability.**
- **Bidirectional bridge output on single power supply.**
- **Low standby power drain. (5.5 mA)**
- **Adjustable deadband and trigger thresholds.**
- **High linearity. (.5% maximum error)**
- **Optional drive for external PNP Transistors.**
- **Wide supply voltage range. (3.2 - 6.0 volts)**

For full specifications refer to the Signetics® Analog Data Manual

Section II - the Encoder

The previous section discussed the basic servo operation, which stated that the sole purpose of the transmitters stick was to control the “length” of a pulse sent to the servo. This section will address how that is performed within the basic transmitter.

For simplicity sake let’s look at the operation of a basic Pulse Positional Modulated (PPM) 4 channel radio (Refer to Figure 1). Here we have two control sticks, each controlling two channels. For now we will just call these channel 1 through 4. The four controls provide input to an “Encoder” which will produce an output suitable to be modulated onto a Radio Frequency carrier.

For now let us concentrate on the input and encoder (Refer to figure 2).

Each axis (channel) of the control stick is connected to a potentiometer (pot for short) which controls the length of a pulse generated by a pulse generator.

As discussed under servo operation, the length of the pulse is varied from 1.0 ms to 2.0 ms with 1.5 ms being the pulse length when the stick is in its center position. For simplicity let us say that both sticks are centered and all four channels are

generating a 1.5 ms pulse.

Since all four pulses can not be sent at the same time, they must be “encoded” into a format suitable for transmission and decoding. To accomplish this the pulses are encoded into a serial string. This creates the problem that if the pulses were just serially sequenced, they would become one long pulse and we could not detect their individual width. To resolve this what the encoder generates is a string of markers defining the start and end of each pulse.

If both sticks were centered, the string would begin with a “start pulse”, which defines the start of the channel 1 pulse, it would be followed 1.5 ms later with a pulse defining the end of the channel 1 pulse and the start of the channel 2 pulse, 1.5 ms later with a pulse defining the end of the channel 2 pulse and the start of the channel 3 pulse, 1.5 ms later with a pulse defining the end of the channel 3 pulse and the start of the channel 4 pulse, and 1.5 ms later with a pulse defining the end of the channel 4 pulse.

We now see, that should you have a radio with more than 4 channels, that the pulse string could continue indefinitely.

After the last pulse we have a reset period, which is

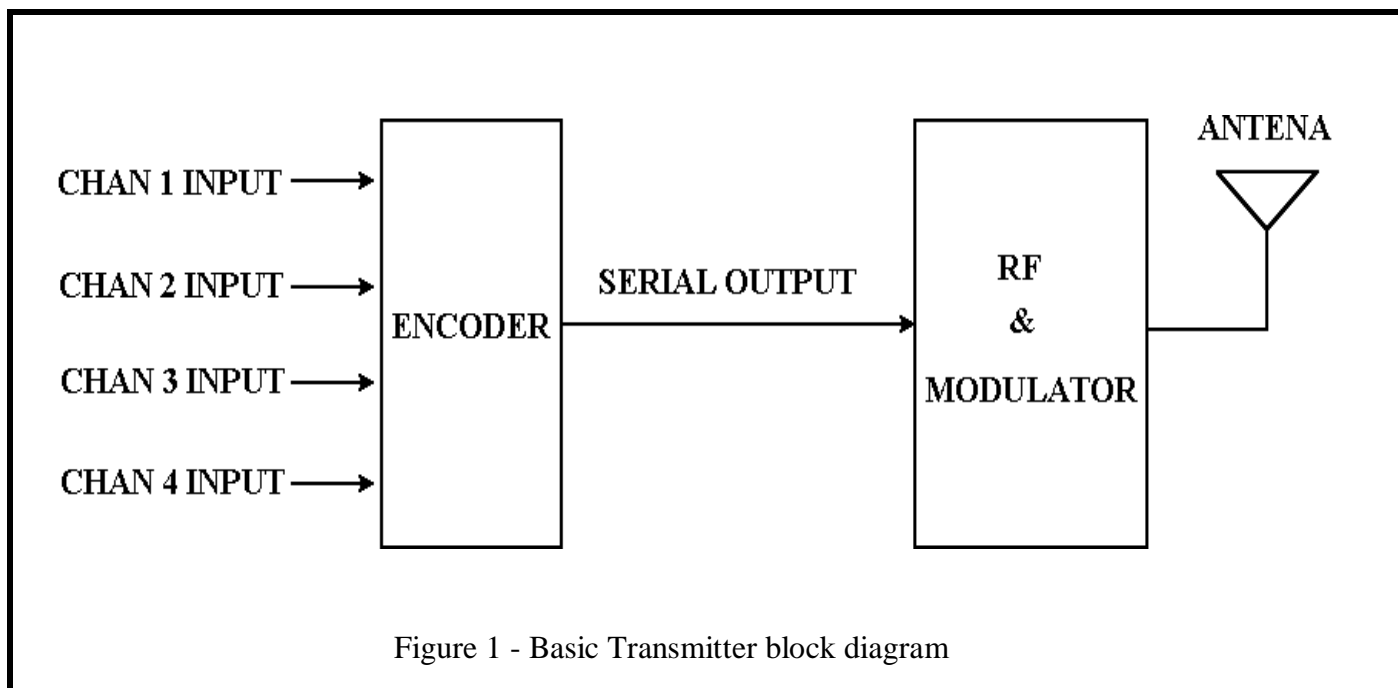

Figure 1 - Basic Transmitter block diagram

required by the decoder, at which time the whole thing starts over again. This overall sequence from the start pulse to the end of the reset period is called a "frame".

A closer look at the stick controlled pulse generators will reveal that in order to achieve the serial encoding, they would not all start at the same time. The first channel pulse is triggered by the start of the frame, the second channel pulse is triggered by the end of the first pulse, the third

channel pulse is triggered by the end of the second pulse, and so on through all channels.

Referring to Figure 3 we see this sequential triggering. I have also altered the pulse widths in this diagram to reflect the channel one pot being centered, the channel 2 pot being centered, the channel 3 pot being at minimum, and the channel 4 pot being at maximum.

Now in early transmitters all this was done with

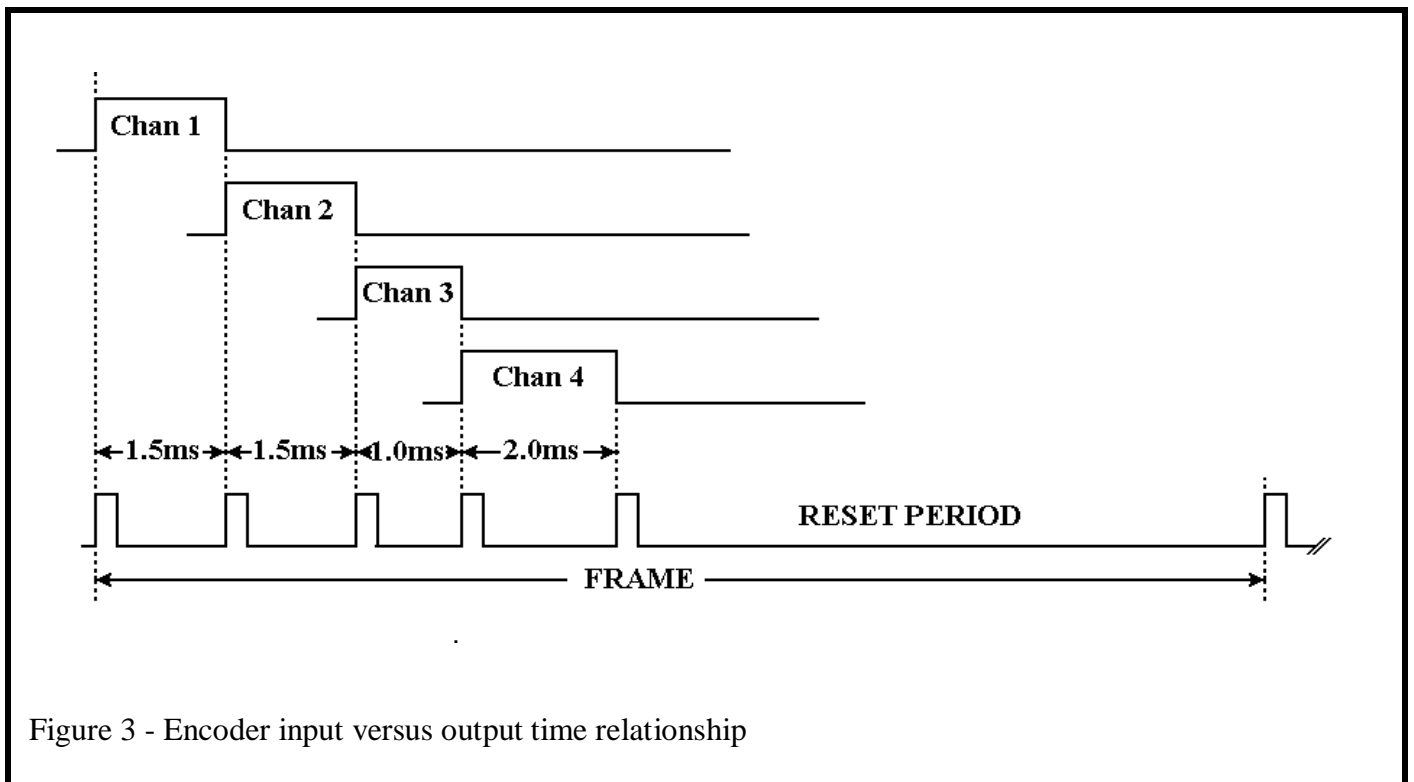
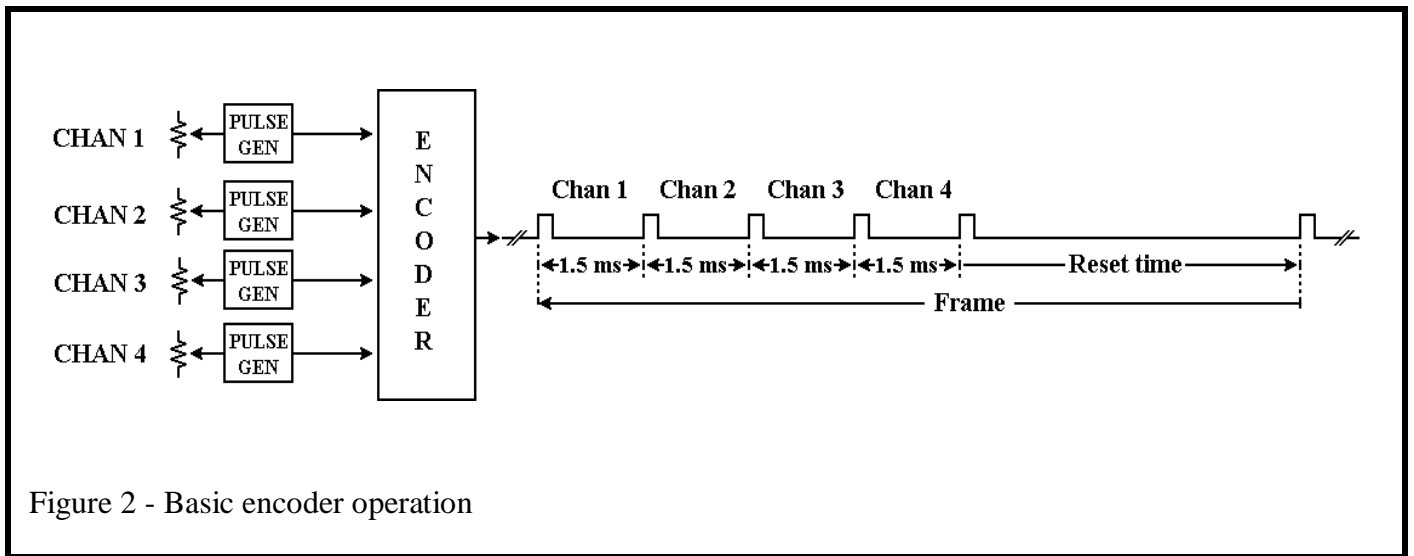

discrete components and single shot circuitry, but as with the servo, Signetics® simplified the operation with the NE5044 “Seven Channel RC Encoder”. This encoder is commonly used in many of our non computer radios.

Looking at Figure 4 we see an example of a Signetics NE5044 IC giving us a complete seven channel radio less the RF circuitry.

Pin 16 is the positive input voltage, pin 8 is ground. The unit will operate on 4.5 to 12 volts dc. Pin 15 is the output from the internal voltage regulator which provides a nominal 5.0 volts which is used on all timing circuits.

Pin 1 through 7 are the inputs for the 7 channels. The pots shown on pin one are the stick and trim

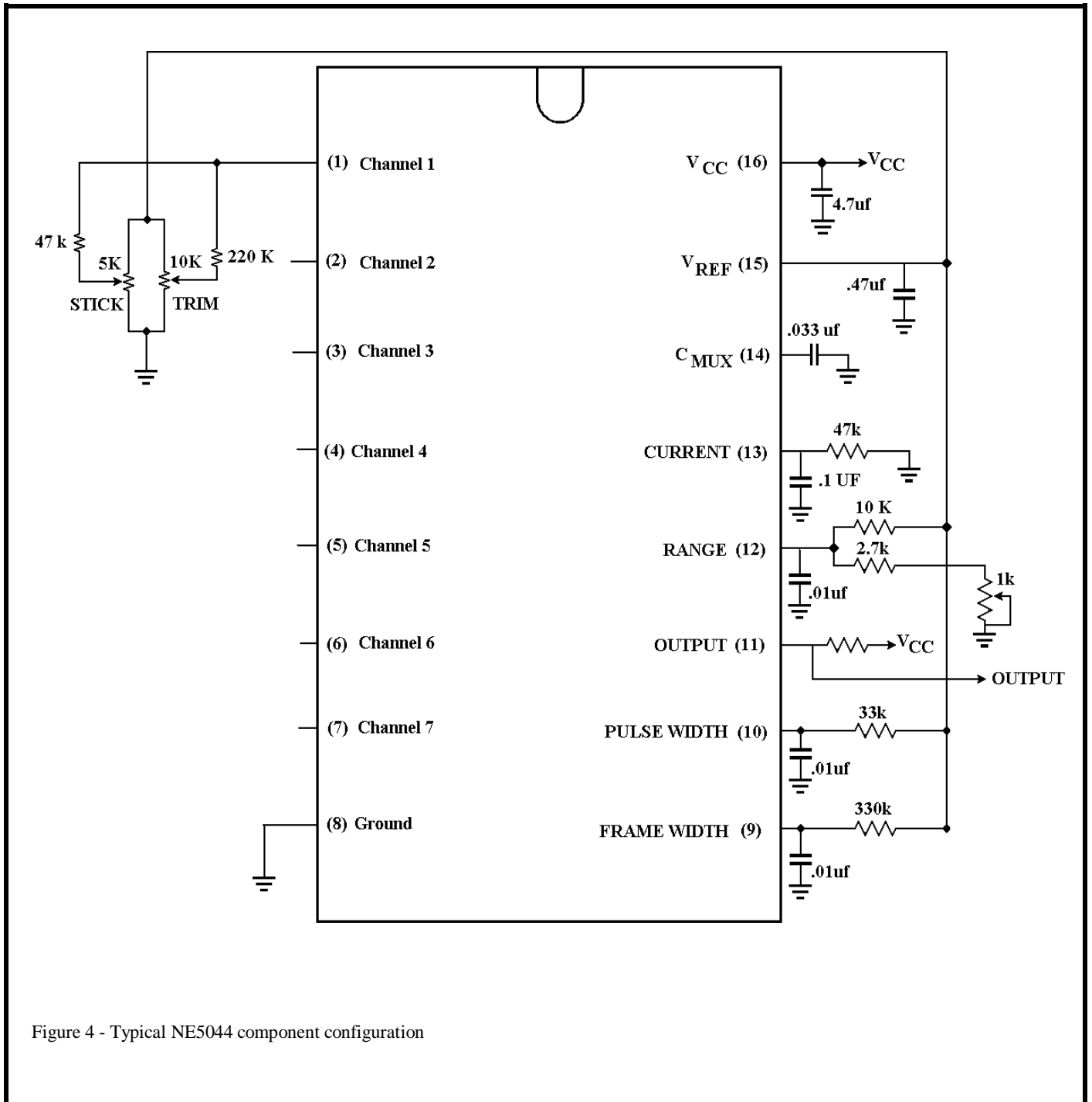

Figure 4 - Typical NE5044 component configuration

pots for channel one and would be duplicated on all inputs used. They are connected across V_{reg} (regulated 5.0 volts) and ground to eliminate variations due to battery voltage drop. The circuitry on pin 10 controls the width of the “output pulse” (normally about 300 us).

The circuitry on pin 9 controls the “frame” width (normally about 20 ms).

Pin 12, 13, and 14 are used to tailor the input voltage change to pulse width. See “Pulse timing circuits” later in article.

The unit is programmed for 3 to 7 channel by grounding the input of pin 4, 5, 6, or 7. That is, by grounding pin 4 (channel 4 input), only the first 3 inputs of the encoder will be used and thus operate as a 3-channel encoder. Grounding pin 5 results in a 4-channel encoder and so on.

Encoder malfunction is minimized in that if any input is shorted to supply voltage or open circuited, all the remaining channels will continue to operate.

Pulse timing circuits - Timing for the stick controls is based on a bidirectional constant current generator which alternately charges and discharges the capacitor on pin 14 (C_{mux}). Charging current is set by the resistor on pin 13 (current). The voltage divider network on pin 12 (range) sets the bottom voltage range the capacitor will be discharged to, the voltage applied by the stick pots on pin 1 through 7 sets the individual voltage the capacitor will be charged to (V_{mux}).

Thus (referring to figure 5) capacitor “ C_{mux} ” starts charging at a linear rate until it reaches the voltage applied at the channels input pin (V_{mux}). When the voltage $V(C_{mux})$ matches the voltage applied on

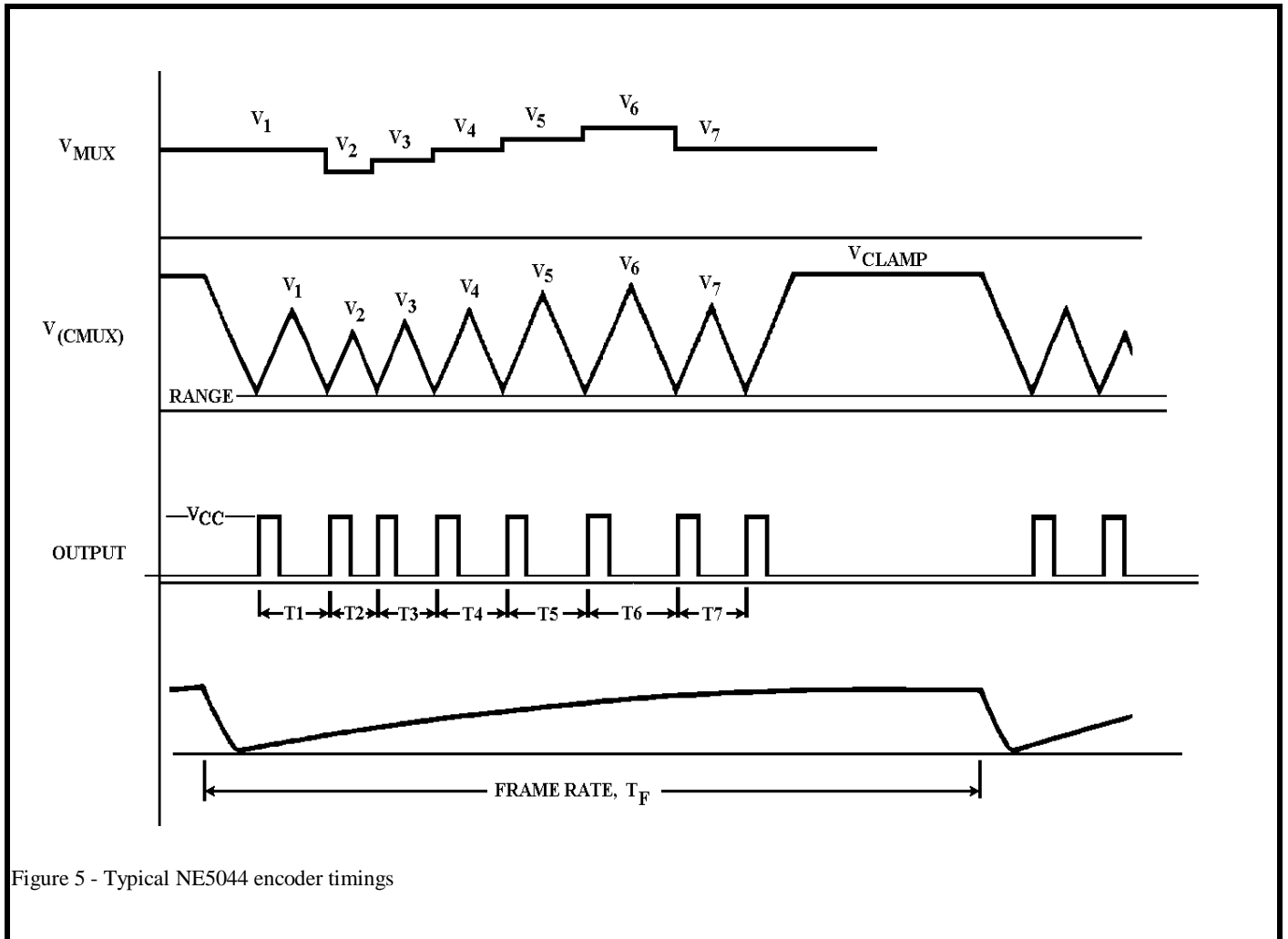

Figure 5 - Typical NE5044 encoder timings

the channel input pin “Cmux” begins a linear discharge to the voltage set by the “range” network. The base width of this linear triangular pattern establishes the time between output pulses.

Although the circuit provided in figure 4 is a working circuit, there are formulas for calculating all components. These can be found in the Signetics® Analog Data Manual.

Servo Reverse - From the above we see that it is the reference voltage applied to the channel input, and not the resistance of the pot, that alters the pulse width. This makes servo reversing a simple matter of reversing the voltage across the pot. This is easily accomplished with a double pole double throw switch as show in figure 6.

Dual Rate - Since the voltage swing applied to the input pin will be reduced by adding a series resistor, adding dual rate only requires that we add a pot in the stick leg to reduce the input swing (Figure 6). The pot is shorted by the switch in high rate, providing max voltage swing. When the switch is opened, the setting of the pot controls how much we reduce the voltage swing (low rate).

Switch operated channels - It may be desirable on some channels (like landing gear) to “switch” the output from full one direction to full opposite direction.

This is accomplished by replacing the “pot” with a resistor divider network and a switch. The resistors selected would provide a voltage shift equal to having the pot at one end of the stick throw or the other. The divider network show in figure 7 would accomplish this in our example circuits..

Channel mixing - Channel mixing, although simple, requires an inverting circuit. The most common method would be to use an op-amp operating as a single supply inverting amplifier. Referring to Figure 8 we see a typical circuit using a LM324 or equivalent. The LM324 is a quad op-amp meaning there are 4 of them in a single 14 pin chip.

In this circuit, the op-amp is operating as an inverting amp (stick pot connected to - input). In this circuit let us assume that the stick pot output voltage is 2.5 volts when the stick is centered. (Remember we put the regulated 5.0 volts on one end of the stick pot and grounded the other.) The op-amp reference (+ input) also has 2.5 volts applied through the divider network. Under this condition the output of the op-amp would also be 2.5 volts.

With the inverting op-amp, as we move the stick pot in one direction, lets say +, the inverted output from the op-amp moves the same amount in the opposite direction (-).

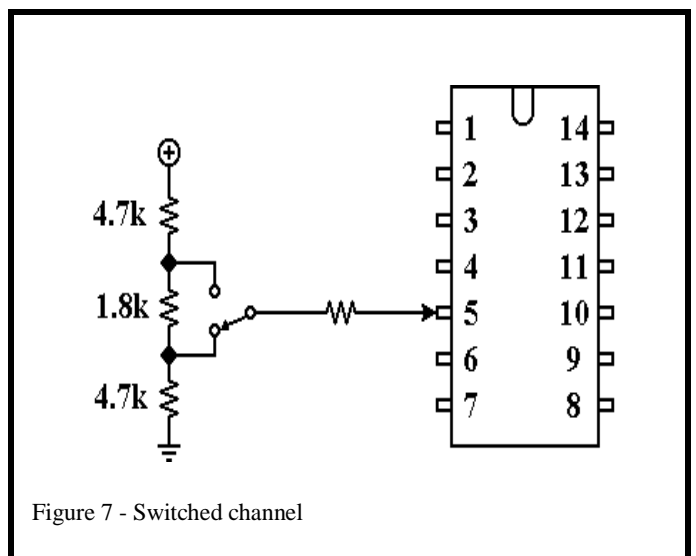
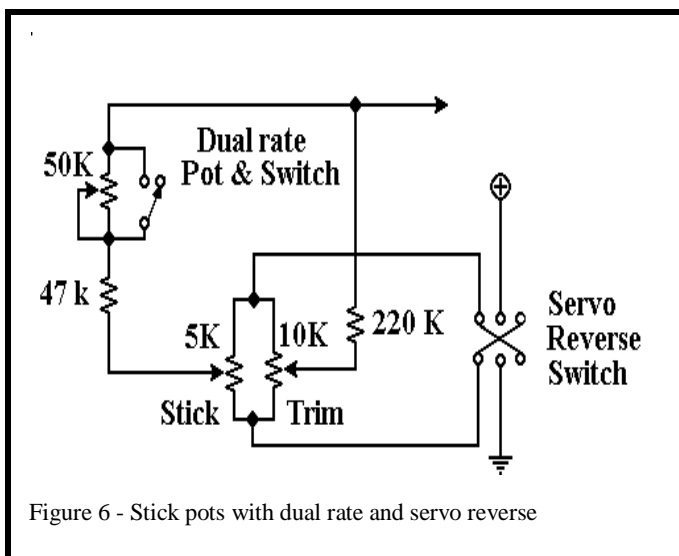

Now look at the “mix-out” 50K pot. It is connected from the op-amp output to the stick pot output. If the mix-out pot is in its center position we will always get 2.5 volts out. Why? because when the stick is centered 2.5 volts is applied to both end of the 50k pot, and the average of 2.5 volts is 2.5 volts. Now as we move the stick to the minus side, lets say to 2.0 volts, the inverted output of the op-amp goes equally as much to the plus side, 3.0 volts, or vice versa. The average of the 2.0 volts on the low side and the 3.0 volts on the high side, would still be 2.5 volts at the center of the mix-out pot.

The amount of mix, and the direction of mix, is then determined by moving the mix pot off center in one direction or the other. This mix output would then be applied to mix-in on another channel (like aileron to rudder if you wanted your rudder to move when you moved your ailerons). Mix in is

shown in Figure 8 on the Stick pot input leg to the op-amp.

Mode I vs Mode II - What is a Mode I and Mode II radio and why do we have them?

Well the answer goes back to the days of reed radios. In a reed radio you did not have a 2 axis stick or fully proportional channels.

Each control had its own self centering switch which you manually pulsed to operate the control. Your two primary switches were rudder (or aileron) on the right side of the transmitter (right hand thumb operated), and elevator on the left side of the transmitter (left hand thumb operated).

Looking at the right switch it moved horizontally. When you moved the switch to the left, the servo went to full left and stayed there. When you

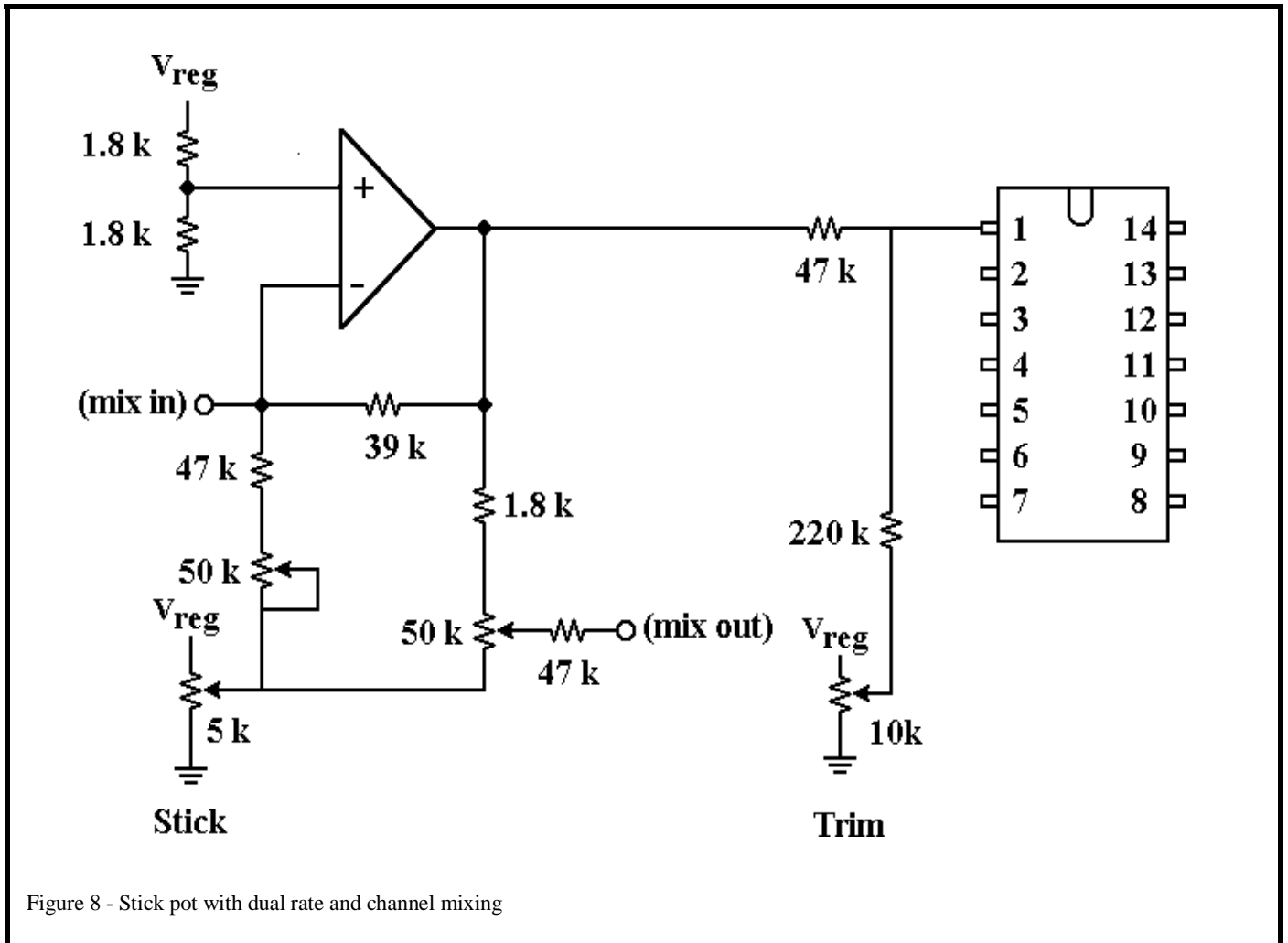

Figure 8 - Stick pot with dual rate and channel mixing

released the switch the servo returned to neutral (These were true self centering servo's). To turn left at less than full throw you would pulse the switch. The same applied to elevator on the left switch except it moved up and down.

When the proportional radio's came out, the sticks were connected so that the right horizontal was aileron, and the left vertical was elevator. This was because reed equipment flyers were use to this mode of operation.

Mode I - Right stick horizontal is aileron, right stick vertical is throttle. Left stick vertical is elevator, left stick horizontal is rudder.

Mode II - Right stick horizontal is aileron, right stick vertical is elevator. Left stick vertical is throttle, left stick horizontal is rudder.

I won't get into the argument of which mode is the best, but most new flyers, with no previous preferences, start with mode II.

Pulse sequencing - Although I know of no valid reason, manufactures have chosen to differ in the position for which channels are placed in the encoded serial output. The stick pot you connect to the encoder channel 1 input defines the function of the first channel. Any stick pot could be connected to any input.

Futaba and Hitec use a sequence of aileron, elevator, throttle, rudder. JR selected throttle, aileron, elevator, rudder. While Airtronics chose to send elevator, aileron, throttle, rudder.

On AM modulation all transmitters will operate all receivers, and if you wanted to use a Futaba receiver with a JR transmitter you would just have to remember that you plug the servo's into the receiver based on the transmitter sequence and not the receiver definition. The receiver does not care which control is on what output.

Now on FM we have a different story. Manufactures have chosen not only to rearrange the pulse sequence but to also select opposite high/low frequency shifts. (We will address the

FM incompatibility in a later article when we cover RF and Modulation).

JR and Airtronics are compatible xmitter to receiver, and Futaba and Hitec are compatible. What this means is that a JR receiver will work with an Airtronics transmitter and vise versa if you remember to plug the receiver according to the transmitter sequence.

Futaba and Hitec are also compatible using the same rules.

If you do choose to operate one manufactures receiver on another manufacturers transmitter, be sure to range test the combination before using it.

Section III - The Decoder

The last section discussed the encoding operation within the transmitter. Accepting that the encoded signal was successfully transmitted to the receiver we will address the decoder operation with this article.

The purpose of the decoder is to reverse the operation of the encoder. Its goal is to take the incoming string of pulses, return them to their original pulse length, and send them out to the proper servo.

To understand the basics of this operation let us refer to Figure 1. This is a hypothetical block diagram of a decoder (For you circuit and electronic nuts I know it is not technically correct, but bear with me for now).

To demonstrate the basic operation let us look at the circuits which I have blocked.

Input pulse shaping - This block represents circuitry which would clean up the input pulses

from the receiver.

Lock-out timer - This blocks output is on and is reset with each incoming pulse. It will time out and return to its on state when an input pulse has not been received for a period of time.

Chan x Flip flop - This blocks output will be turned on or off with each input pulse based on the status of the previous block. If the previous block is on it will turn on, if the previous block is off it will turn off (or stay off if it's not on). Its output is positive when turned on.

Notice that the input pulse is applied to all flip-flop blocks.

Now then assuming that all circuits are in their static state, where the lock-out timer is on, and each flip-flop is off, we are ready to start receiving our input string. As covered in encoding, our input string begins with a start pulse and is followed by four pulses spaced to represent the width of the four channel outputs (Refer to figure 2). For this example we will again assume

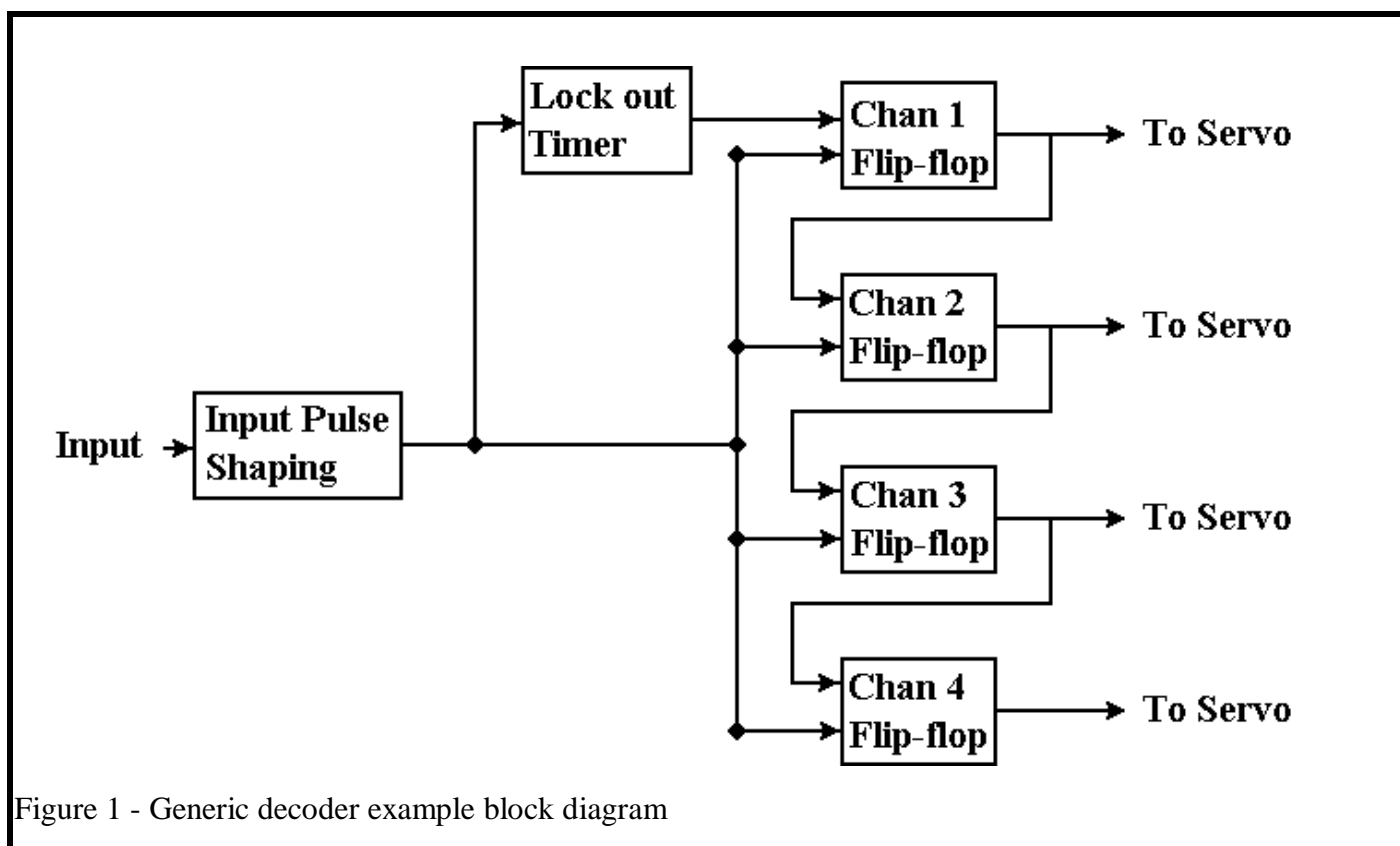

Figure 1 - Generic decoder example block diagram

that both sticks are centered and the spacing between pulses is 1.5 ms.

When the first pulse, the start pulse, is received it will only turn on the Chan 1 flip-flop. The channel 1 flip flop is conditioned to turn on by the fact that the lock out timer is on. Chan 2 through 4 will not turn on because none of the previous channels are on. Also this pulse will reset the lock-out timer and its output will be off. Now 1.5 ms later the second pulse is received. This is the pulse which defines the end of channel 1 and the start of channel 2. Since the lock-out timer is now reset, the only chan flip-flop conditioned to turn on is the Chan 2 flip flop. Also since the channel 1 flip flop is on and the lockout timer off, the channel 1 flip- flop will be turned off. The lock-out timer will be reset again with this pulse even though it hadn't turned back on.

What we now have is that the channel 1 output to the servo was on for 1.5 ms. and we have just turned on the channel 2 flip-flop.

Now 1.5 ms later we will receive the third pulse. This is the pulse defining the end of channel 2 and the beginning of channel 3. Since the lock-out timer is still reset, the only chan flip-flop conditioned to turn on is the Chan 3 flip flop. Also since the channel 2 flip flop is on and the channel 1 flip-flop is off, the channel 2 flip- flop will be turned off. The lock-out timer will be reset again.

What we now have is that the channel 2 output to

the servo was on for 1.5 ms. and we have just turned on the channel 3 flip-flop.

This sequence will repeat itself through all four channels.

Now, if you recall when we were discussing the encoder operation, we stated that the last channel pulse was followed by a reset period which was required by the decoder. The reset period is a period of time long enough for the lock-out timer to return to its on position. This must occur before the next frame of pulses is received. This period would be longer than the maximum time between pulses, longer than 2.0 ms, and yet short enough to ensure that it was reset before the next frame of pulses was received. A typical period would be 5 to 6 ms which would allow the dropping of a single pulse without resetting the unit. When the lock-out timer resets, it resets any flip-flop that for some reason was on. This ensures that if we had lost a pulse in the transmission, that a channel flip-flop was not left on. This also ensures that we will “sync” the receiver to the transmitter within one frame after turning on the equipment.

Remember this article is for your information only and is not a design, service, or operational manuals. Although I have tried hard to present accurate data, it comes with no guarantees.

For what it's worth—Al Coelho

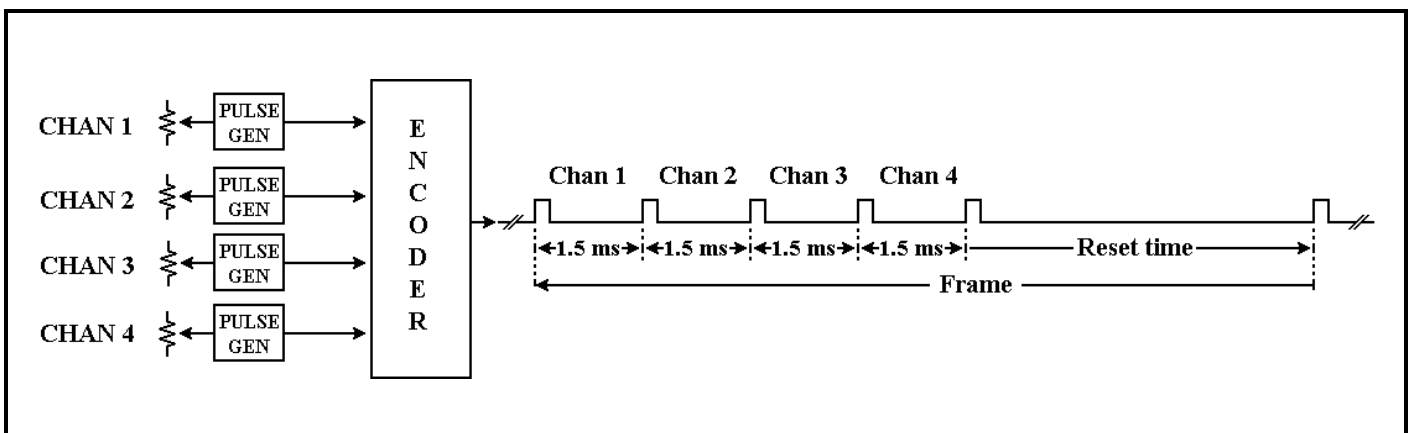

Figure 2 - Encoder timing

Section IV - R/C Radio Transmission

We have already discussed the theory of operation of our basic PPM radio. Now lets address some of the terms which are associated with the transmission of the signal to the receiver.

AM, FM, PPM, PCM, Single conversion, Dual conversion, Wide band, Narrow band, Computer radios. Are these terms confusing to you? If so lets try to clear some of it up.

Let us start by defining the basic, Radio Frequency.

Radio Spectrum: *That part of the general fre-*

quency spectrum between 10kHz to 30,000 mHz. Generally an alternating current frequency whose electromagnetic field can be radiated over great distances. (Or a frequency which transmits)

When you purchase a radio you specify a channel for it to operate on. The channel defines the frequency that the Carrier Signal is transmitted on. The carrier signal is the radio frequency to which your encoded data is superimposed on to carry it to the receiver.

Within the United States, the use of the radio frequency spectrum is controlled by the Federal Communications Commission (FCC). Regulations con-

72 Mhz Frequencies Aircraft use only			
Chan	Freq	Chan	Freq
11	72.250	36	72.510
12	72.030	37	72.530
13	72.050	38	72.550
14	72.070	39	72.570
15	72.090	40	72.590
16	72.110	41	72.610
17	72.130	42	72.630
18	72.150	43	72.650
19	72.170	44	72.670
20	72.190	45	72.690
21	72.210	46	72.710
22	72.230	47	72.730
23	72.250	48	72.750
24	72.270	49	72.770
25	72.290	50	72.790
26	72.310	51	72.810
27	72.330	52	72.830
28	72.350	53	72.850
29	72.370	54	72.870
30	72.390	55	72.890
31	72.410	56	72.910
32	72.430	57	72.930
33	72.450	58	72.950
34	72.470	59	72.970
35	72.490	60	72.990

75 Mhz Frequencies Surface use only			
Chan	Freq	Chan	Freq
61	75.410	76	75.710
62	75.430	77	75.730
63	75.450	78	75.750
64	75.470	79	75.770
65	75.490	80	75.790
66	75.510	81	75.810
67	75.530	82	75.830
68	75.550	83	75.850
69	75.570	84	75.870
70	75.590	85	75.890
71	75.610	86	75.910
72	75.630	87	75.930
73	75.650	88	75.950
74	75.670	89	75.970
75	75.690	90	75.990

6 Meter Frequencies Aircraft or Surface use FCC License Required			
Chan	Freq	Chan	Freq
00	50.800	N/A	53.100
01	50.820	N/A	53.200
02	50.840	N/A	53.300
03	50.860	N/A	53.400
04	50.880	N/A	53.500
05	50.900	N/A	53.600
06	50.920	N/A	53.700
07	50.940	N/A	53.800
08	50.960		
09	50.980		

27 Mhz Frequencies Aircraft or Surface use			
Chan	Freq	Chan	Freq
A1	26.995	A4	27.145
A2	27.045	A5	27.195
A3	27.095	A6	27.255



trol not only the frequency you can transmit on, but also the maximum power and bandwidth you can use. There may also be controls placed on the type of data sent, hours of operation and location of transmission.

Frequency assignment: *The frequencies defined by the FCC for use by our hobby.*

We are currently allocated frequencies in the 27, 72, and 75 mhz and the 6 meter ham band. These frequencies and their associated channel numbers are listed in the tables.

Most aircraft operate within the 50 channels (frequencies) assigned in the 72 mhz band which are restricted to aircraft use. **The following definitions apply to these channels.** For additional information and limitations refer to FCC part 95 of CFR 47.

No license is required for the 27, 72, or 75 mhz bands. Use of the Ham Band frequencies does require a Ham Band license.

Band Width: *The maximum allowable deviation from the defined carrier frequency (assigned frequency) which you may use.*

Our current frequencies are allowed a maximum band width of 20khz (20,000 cycles). This would be 10khz above and 10khz below our assigned frequency. From our chart we see that our frequencies are 20khz apart. If we were transmitting on channel 48 (72.750), then our signal could vary from a low of 72.740 to a high of 72.760. Channels above or below us could transmit to their bandwidth boundaries but would not overlap our usable space.

Beyond the bandwidth allowed, your transmission must be attenuated to a defined level. This attenuation is normally defined in Decibels, which is a method of measuring power. In general, a +/- of 3 db equates to twice/half the power. The scale is logarithmic, and as such can easily measure large variations. A signal which is down (reduced) 3 db is 1/2 the original power. Down 6 db is 1/2 of 3 db

or 1/4 the original power. -9 db would be 1/2 the power of -6 db or 1/8 the power of the original signal.

Our uses of the frequency states that the signal must be -55 db at the limits of our allocated bandwidth. This equates to a power of less than 1 10,000 th of the original power.

Narrow vs Wide Band Operation:

Wide band: *A term used in R/C to describes a system which utilizes a 40 Khz maximum bandwidth. This was termed Silver Stickered.*

Narrow Band: *A term used in R/C to describe a system which utilizes a 20 Khz maximum bandwidth. This was termed Gold Stickered.*

These terms were created to identify the evolution of bandwidth restrictions in getting from our initial 72Mhz allocation to our current 50 channel operation. Initial operation in the 72Mhz band used equipment which operated at an 80 Khz bandwidth. Newer equipment operating in the 40 Khz bandwidth was introduced around 1986 and is what is know today as wideband. This equipment operated on channel 38 thru 56 (even numbered)

A two part evolution to 50 channel operation began in 1988. First the use of the old 80 khz bandwidth equipment became illegal on Dec 20, 1987. Twelve new channels 12 thru 34 (even numbered) were allocated to replace the old 80 khz bandwidth channels. These channels were defined as narrow band and were required to operate in a 20Khz bandwidth.

Wide band equipment continued in use on the upper channels until 1991 when the remaining channels were implemented. Most clubs banned the use of wide band transmitters at this time.

The use of wide band transmitters became illegal under FCC rule on March 1, 1998.

Power output: *The maximum power which may be transmitted. Usually defined in Watts or a fraction there of. For the 72Mhz bands used in our hobby*



this is defined at .75 Watts maximum.

Modulation: *A method of superimposing a data signal onto a carrier frequency.*

Amplitude Modulation (AM): A method of modulation where the strength of the carrier frequency (amplitude) is varied based on the data signal.

Frequency Modulation (FM) A method of modulation where the frequency of the carrier signal is varied based on the data signal.

FM is generally defined as being less sensitive to interference than AM modulation.

Unlike radio or TV where constantly varying audio or video data is applied to the carrier, we apply on/off data to the carrier. In AM mode this means that the carrier will switch from one power level (amplitude) to the other to represent a data bit. In FM the frequency is changed from a frequency below (or above) the assigned carrier frequency to a frequency above (or below) below the carrier frequency to represent a data bit. This frequency shift in our environment is usually 2.5 khz.

Positive vs Negative Shift: We've stated that when working in FM mode, Futaba and Hi-Tech are compatible, and that JR and Airtronics are compatible. This is because of the way that each has chosen to implement the frequency shift to represent a data bit. One has selected to send the lower frequency normally and shift to the higher frequency to represent a data pulse, while the other sends the higher frequency normally and shifts to the lower frequency to represent a data bit. Both Airtronics and Hi-Tech now offer a transmitter where you can select the shift mode which means that they can be set to work with either brand.

Single vs Dual Conversion receivers:

As mentioned in the introduction, early R/C equipment operated on a carrier wave only which was not modulated with any data. When the button was pushed on the transmitter, the carrier frequency was turned on and when received by the receiver a relay was activated. These units which were extremely

susceptible to interference were still in use into the 60's. With the exception of some 400 mhz equipment all units were on the same 27.255 mhz frequency and two people never flew at the same time.

With the popularity of R/C growing, more frequency were allocated (still on 27mhz) and more sophisticated equipment was used. This included the use of a modulated carrier frequencies and the superhetrodyne receiver. The superhetrodyne receiver (which is what we use today) had a front end which was tuned to the carrier frequency, followed by an IF (intermediate frequency) section, which was tuned to the industry standard 455 khz. An internal oscillator was required in the receiver to beat against the incoming carrier frequency and produce the 455 khz IF frequency. This beating of the frequencies, called "hetrodyne" is the basic operation that we call conversion today.

The advantage of this conversion to 455 khz is that it is easier to tune the bandwidth of this lower frequency and that one receiver, with a fine tuned IF bandwidth, can be made to operate across a wide carrier spectrum by changing the beat oscillators frequency. Applying this to our environment we see that the front end (RF section) of our receivers are tuned to a bandwidth which covers multiple channels. An internal crystal controlled oscillator, who's frequency is controlled by the Xtal plugged into the receiver, generates the beat frequency necessary to convert the incoming signal to 455 khz. The 455 khz IF section of our narrow band receiver is tuned to pass frequencies from 445 to 465 khz (20 khz).

If you are operating on channel 48, your transmitter is sending a carrier on 72.750 mhz. Your receiver Xtal would be 73.205, or 455 khz above the carrier frequency (most receivers use an over crystal). The result is that when you frequency enters the receiver, and beats against the oscillator, it produces a 455 khz result. If someone was flying on channel 47, 72.730, their frequency would also enter your receiver and beat against the oscillator. There frequency, 72.730, beat against the oscillator 73.205 would produce a beat frequency of 475 khz (73.205 minus 72.730). Since your IF is tuned to pass frequencies in the range of 445 to 465 khz the channel 47 (or any other channel) would be rejected.



We now also see why wide band receivers, which has an IF range of 435 to 475 khz (40 khz), can not operate at the same time with a transmitter one channel above or below them.

With this basic understanding of a single conversion receiver, let us expand this to a dual conversion unit. A dual conversion receiver does just as its name implies. It converts the incoming frequency twice. As with the single conversion, the IF is still a narrow tuned 455 khz section. But instead of converting the incoming frequency directly to 455 khz, it is converted twice, first to 10.7 mhz and then to 455 khz. The receiver xtal in a dual conversion receiver is 10.7 mhz above the transmitter frequency and a second oscillator (which is not plugable) converts the 10.7 mhz to 455 khz .

Dual conversion offers additional interference rejection and eliminates the 2IM interference caused by two other transmitters operating 23 channels apart which generates a 460 Khz beat frequency.

PPM vs PCM: PPM (Pulse Positional Modulation) and PCM (Pulse Coded Modulation) are confusing term. The word modulation should be replaced with the word encoding. Both PPM and PCM encoding is modulated onto a carrier frequency and could use either AM or FM. PCM is normally provided only on FM based systems.

In PPM encoding we saw that marker bits, which are spaced the width of the servo pulse, is what is modulated onto the radio frequency. This means that the pulse sent by the RF module is of a time duration only. For example, if the signal generated by the elevator stick in the transmitter is 1.7 ms long then the PPM marker pulses will be 1.7 ms apart. The receiver then receives this 1.7 ms spaced signal, processes it and then sends it to the servos. This encoding scheme is simple and effective, and has become the accepted method for RC for the last 20 or so years. It has one serious drawback, and that is, if for any reason, interference alters the pulse train in any way, the Receivers decoder will become confused, and the servos would be sent wrong position data. This would produce erratic, random operation, commonly known as "glitching".

With the advances in microelectronics, it became possible to design cost-effective PCM systems. In a PCM system, a microprocessor (computer) replaces the encoder found in the transmitter of a basic PPM system. In the PCM system, control stick positions do not control pulse generators but are inputs into A/D (analog to digital) converters which convert the stick position into binary numbers, The microprocessor then assembles all the numbers from all the channels into a data string, calculates a checksum, and outputs a data frame to the RF module for transmission to the receiver.

Aside from sending a digital representation of the pulse width, the main difference between the PPM and PCM radios is the addition of the checksum. The checksum is nothing more than a "total" count of the binary codes generated for each channel within a specific frame. The receiver also has a checksum counter, and as the frame is received, the receiver's checksum counter "totals" the binary codes. Once a frame has been received, the receivers checksum is compared with the checksum sent by the transmitter. If the two totals are equal the receiver passes the processed channel data on to their respective servo. If the two totals from the checksum counters are different, the receiver discards that frame of data and the servo's hold their current position.

This means that the Receiver has a means to distinguish good and bad data frames, i.e., frames that have interference-caused glitches in them. The Receiver will then reject bad frames, and maintain the servos at the last known good position. This is known as "Hold".

Some PCM radios have an added feature, called "Failsafe". If the Receiver has not received at least one good frame in more than 1 sec. (this delay is programmable in some radios), it will command the servos to a preset "failsafe" position . As soon as the Receiver receives a good frame, it will come out of Hold or Failsafe, and send that position data to the servos.

This is why an aircraft with a PCM radio will not exhibit the "jitters" like a PPM radio when an

unwanted signal is introduced into the system.

Early PCM systems divided the servo's rotation into 256 discrete positions. What this meant is that the arc of the servo throw is divided into 256 steps and the servo pulse width generated by the decoder is based on the binary number 1 through 256. A binary 1 would represent maximum throw in one direction with a binary 256 representing maximum throw in the opposite direction. A binary 128 would represent centered.

Modeling demands soon forced manufactures to provide more precision 512 step systems, and finally the 1024 systems. These higher resolution systems required the transmitting of more data between the transmitter and receiver which reduced the number of updates per second that the servo received. The typical PCM radio send about 20 frames per second versus the 50 frames per second sent by a PPM system. To achieve 256 steps, 8 data bits per channel must be sent or a total of 80 data bits for a 10 channel system. 512 system would require 9 bits per channel for a total of 90, and 1024 requires 10 bits per channel for a total of 100. Adding the sync and checksum data may extended each of these an additional 16 to 20 bits.

Although the PCM method of operation will eliminate the "Jerking" when an interference situation occurs, it should be noted that PPM and PCM encoding/decoding has nothing to do with the capability of the receiver to reject unwanted signals.

The PCM concept of encoding/decoding was originally developed in the pre 1991 era to address the interference problems of those days. With the new narrow band, dual conversion receivers, used today, PPM receivers may work as reliably in may area. In todays narrow band environment, FM and dual conversion usually reduces the receivers susceptibility to interference over AM or single conversion, with dual conversion being the most influential factor.

The Computer Radio:

The term "PCM" and "Computer Radio" are not analogous. Although all PCM radios are computer radios, not all "computer radios" are PCM. Today's computer radios are available in both PPM and PCM versions. The "computer radio" is probably the most significant advancement of the last decade. In the computer radio, the transmitters encoder has been replaced with a microprocessor. Once this was done, the capability of controlling the servo pulse became unlimited. Todays computer radio's not only allow full control over the throw, rate, linearity, and reversing of the servo's operation, but also provide many additional mixing features, while allowing you to setup and store these configuration for multiple aircrafts.